



WWW.ICEUSA.COM  
888-ICE-USA1

# ICE® MODEL 7E EXCAVATOR - MOUNTED HYDRAULIC VIBRATORY DRIVER/EXTRACTOR

Excavator bucket circuit provides all hydraulic requirements.

Gear case design provides maximum vibrator speed and light weight.

Clamps available for single & double sheet piling, H-Beams, caissons to 4' (1220 mm), timber, concrete and pipe piles.

Optional gooseneck available for longer piles and greater reach.

Drives and extracts H-Beams, sheet piles, trench plates, pipe piles, guardrail posts and more.

360o swivel allows approach to task from any direction.

Adaptable for underwater operation.



## MODEL 7E EXCAVATOR-MOUNTED PILE HAMMER

Eccentric moment	612 in-lbs	70.5 kg-m
Maximum frequency	2500 vpm	
Maximum centrifugal force	55 tons	485 kN
Amplitude (free w/o clamp)	0.51 in	12.9 mm
Line pull for extracting	17 tons	147 kN
Crowd capability	17 tons	147 kN
Weight with standard clamp	3425 lbs	1552 kN
Non-vibrating Weight	1010 lbs	457 kN
Height overall (HH)	53 in	1334 mm
Height to pin without clamp (H)	31 in	788 mm
Length (L)	41 in	1038 mm
Width (W)	30 in	757 mm
Throat width (TW)	12.6 in	320 mm
Maximum pressure	4640 psi	320 bar
Maximum flow	60 gpm	225 lpm
Maximum power	160 HP	120 kw

\* Does not include excavator stick yoke that adds 16"-20" (400-510 mm)

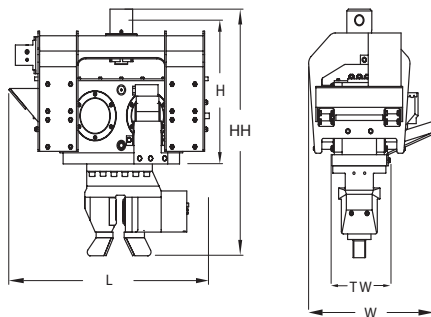

## PERFORMANCE WITH CAT 330C EXCAVATOR

Frequency at low pressure	2500 vpm	42 Hz
Frequency at high pressure	1700 vpm	28 Hz

## PERFORMANCE WITH CAT 325C EXCAVATOR

Frequency at low pressure	2500 vpm	42 Hz
Frequency at high pressure	1450 vpm	24 Hz



Designed and manufactured in USA by ICE®  
World leader in cost-effective foundation equipment since 1974.

Constant improvement and engineering progress make it necessary that ICE®, Inc reserve the right to make specification changes without notice.  
Please consult ICE® for the latest available information. © International Construction Equipment, Inc. All rights reserved. Jan 2015