

ICE® Model 50B Hydraulic Vibratory Driver/ Extractor with Model 580T Power Unit



WWW.ICEUSA.COM
888-ICE-USA1

Combines high frequency (1600 vpm) and large eccentric moment (5,000 in-lbs, 57 kg-m)
580 HP (433 kW) CAT C15 meets EPA Tier 4/EU Stage IV engine emission regulations
Up to 100 tons (1000 kN) line pull for extraction



ICE Model 50B Vibratory Pile Hammer

Eccentric moment	5000 in-lbs	57 kg-m
Maximum frequency	1600 vpm	
Driving Force	187 tons	1670 kN
Centrifugal force	182 tons	1620 kN
Amplitude (free w/o clamp)	1.3 in	32 mm
Standard line pull for extracting	65 tons	600 kN
Maximum line pull for extracting	100 tons	900 kN
Weight (no clamp or hoses)	12555 lbs	5695 kg
Non-vibrating Weight	4560 lbs	2070 kg
Height without clamp (H)	84 in	2135 mm
Length (L)	98 in	2485 mm
Width (W)	21 in	530 mm
Throat width (TW)	14.25 in	362 mm
Hydraulic hose length	150 ft	45 m
Hydraulic hose weight	1555 lbs	705 kg
Height with sheeting clamp (HH)	122 in	3095 mm
Weight with sheeting clamp & 1/2 hoses	15530 lbs	7045 kg
Height with beam & caisson clamps	115 in	2915 mm
Weight with beam, caisson clamps & 1/2 hoses	19450 lbs	8820 kg

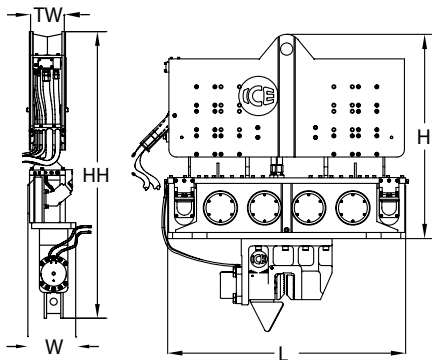

ICE Model 580T Power Unit

Engine	Caterpillar C15	
EPA/EU Emissions rating	Tier 4	Stage IV
Power	580 HP	433 kW
Operating speed	1800 rpm	1800 rpm
Maximum motors pressure	5500 psi	380 bar
Motors flow (no load)	160 gpm	610 lpm
Clamp pressure	4500 psi	310 bar
Clamp flow	6 gpm	20 lpm
Weight (w/ full fluid & 1/2 fuel)	16350 lbs	7420 kg
Length	160 in	4040 mm
Width	73 in	1855 mm
Height	100 in	2540 mm
Hydraulic oil capacity	430 gal	1630 liters
Fuel Capacity	170 gal	640 liters



DESIGNED AND MANUFACTURED IN USA BY ICE®

WORLD LEADER IN COST-EFFECTIVE FOUNDATION EQUIPMENT SINCE 1974.

Constant improvement and engineering progress make it necessary that ICE®, Inc reserve the right to make specification changes without notice.
Please consult ICE® for the latest available information.